

# Thermal lens spectrum of organic dyes using optical parametric oscillator

Achamma Kurian<sup>1</sup>, K.P. Unnikrishnan, D. Sajan George, Pramod Gopinath, V.P.N. Nampoorei\*, C.P.G. Vallabhan

*International School of Photonics, Cochin University of Science & Technology, Cochin 682022, India*

Received 1 April 2002; accepted 25 April 2002

## Abstract

The wavelength dependence of thermal lens signal from organic dyes are studied using dual beam thermal lens technique. It is found that the profile of thermal lens spectrum widely differ from the conventional absorption spectrum in the case of rhodamine B unlike in the case of crystal violet. This is explained on the basis of varying contribution of nonradiative relaxations from the excited vibronic levels.

© 2002 Elsevier Science B.V. All rights reserved.

*Keywords:* Thermal lens; OPO; Laser dyes; Nonradiative relaxation

## 1. Introduction

In the last three decades, we have witnessed the development of a number of techniques for non-destructive characterization of the thermal, optical and structural properties of materials based upon the photothermal techniques such as photoacoustic spectroscopy, photothermal lensing spectroscopy and photothermal deflection spectroscopy. In these methods, the signal magnitude is directly related to temperature rise in a light-illuminated material and to the amount of heat generated via

optical absorption and subsequent nonradiative relaxation. Among these photothermal techniques thermal lensing TL is a versatile and viable technique for exploring nonlinear processes taking place in organic materials and dyes. Eversince the discovery of photothermal lensing effect by Gordan et al. [1] this technique of monitoring non-radiative relaxation in excited molecule has been refined by various researchers to suite for the study of various phenomena related to light-matter interactions [2–10]. Most important modification of the thermal lens technique is the dual beam method developed by Long et al. [11] so that one can record the thermal lens spectrum of samples. Detection of thermal lens signal has been improved later on by incorporating optical fibre so as to introduce flexibility in the experimental configuration [12]. One of the important features of this

\* Corresponding author

*E-mail addresses:* [achammakurian@rediffmail.com](mailto:achammakurian@rediffmail.com) (A. Kurian), [vpnnampoorei@cusat.ac.in](mailto:vpnnampoorei@cusat.ac.in) (V.P.N. Nampoorei).

<sup>1</sup> Present address: Catholicate College, Pathanamthitta 689645, India.

technique is that it is a highly sensitive method for measuring the absorbance of light in a multitude of samples based on physical changes that occur in the sample during irradiation.

When a medium is illuminated with Gaussian laser radiation, some of the incident energy is absorbed by the molecules in the ground state, and are excited to higher energy states. The excess energy acquired by the molecule can be dissipated in many ways. The non-radiative decay produces localized temperature rise, creating a refractive index gradient in the medium so that the medium acts as a lens-like optical element, called thermal lens. The focal length of the induced thermal lens by pulsed laser irradiation is given by [13,14]:

$$\frac{1}{f} = \frac{1}{f_0} \left( 1 + \frac{2nt}{t_c} \right)^{-2}$$

$$\frac{1}{f_0} = \frac{4lDN\sigma h\nu n^2 H}{kJ\omega^{2n+2}} \left( \frac{dn}{dT} \right) \left( \frac{2}{\pi} \right)^n, \quad t_c = \frac{\omega^2}{4D},$$

$$D = \frac{k}{\rho C_p}, \quad H = \int_0^t p(t) dt \quad (1)$$

where  $f$  is the time-dependent focal length of the thermal lens,  $f_0$  is the focal length just after heating pulse,  $t_c$  is the characteristic time constant of decay,  $l$  is the sample length,  $D$  is the thermal diffusivity,  $N$  is the number of molecules,  $\sigma$  is the cross-section of absorption,  $\nu$  is the frequency of the heating laser,  $h$  is the Planck's constant,  $n$  is the number of photons,  $H$  is the total output energy of the laser,  $k$  is the thermal conductivity,  $J$  is the Joule's constant,  $\omega$  is the beam radius,  $\rho$  is the density,  $C_p$  is the specific heat and  $P(t)$  is the intensity of the heating laser. The probe beam through the TL will be affected and the TL signal is usually measured as the relative change in the probe beam center intensity given as:

$$S_p = S_{(t=0)} \left( 1 + \frac{2t}{t_c} \right)^{-2}$$

$$S_{(t=0)} = \frac{5 \ln(10) A E_0}{\omega^2 \lambda \rho C_p} \frac{dn}{dT} \quad (2)$$

where  $E_0$  is the energy of the pump laser.

In the present experiment, changes in the probe beam intensity results from the wavelength-dependent heating of the sample by absorption of the pump beam. A plot of these intensity changes, therefore, provides a characteristic signature of the absorption mechanism of the samples. Most of the studies reported earlier used tunable dye lasers as the pump beam [13]. One of the drawbacks of dye lasers is the limited range of tunability. The present paper describes the use of TL effect to record absorption spectrum of organic dyes in methanol using optical parametric oscillator (OPO) as the excitation source since optical parametric devices provide wide and continuous wavelength coverage, easy and rapid wavelength tunability, high-energy output and the advantage of being all solid state.

## 2. Experimental

The experimental setup of dual beam thermal lens technique employed in the present investigation is shown in Fig. 1. In dual beam configuration, separate lasers are used for pump and probe beams. This technique is more advantageous since only a single wavelength (probe) is always detected and there needed no correction for the spectral response of the optical elements and detector. Moreover one can record TL spectra only by dual beam setup. The pump beam used for the present study is the radiation from an OPO (Quantaray mopo-700) with tunable output in the range 460–620 nm. Radiation of wavelength

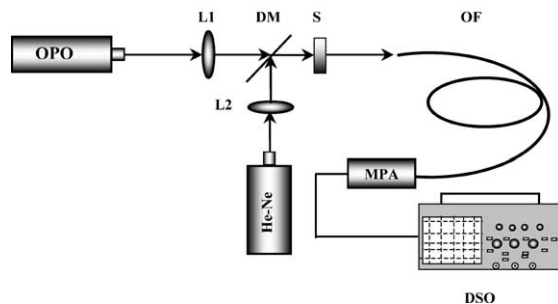

Fig. 1. Schematic diagram of the experimental set up. L1, L2—Lens; DM—dichroic mirror; S—Sample; OF—optic fibre; MPA—monochromator-PMT assembly; DSO—digital storage oscilloscope.

632.8 nm from a low power (1.5 mw) intensity stabilized He–Ne laser source is used as the probe beam. Samples in a quartz cuvette (1 mm) are kept one confocal length past the beam waist. Hu et al. demonstrated that this configuration enhances the thermal lens signal [2]. The probe beam is made to pass collinearly through the sample using a dichroic mirror. An optical fibre mounted on XYZ translator placed at the beam center in the far field serves simultaneously as the finite aperture as well as the detector. The other end of the fibre is coupled to a monochromator-PMT assembly which is set at 632.8 nm. The signal output from PMT is processed using a digital storage oscilloscope (Tektronix, TDS 220). The present work is done at a temperature of 26 °C. The thermal lens spectra are normalized to account for the spectral profile of the OPO output.

The absorption spectrum of the sample is recorded using a UV-Vis-IR spectrophotometer (Jasco V-570). For the fluorescence study, the front surface emission is collected and focused by a lens to the entrance slit of a 1 m Spex monochromator, which is coupled to a PMT having an S20 cathode. The PMT output is fed to a lock-in amplifier. The emission wave length is scanned in the specified region (500–640 nm). Studies on rhodamine B and crystal violet are reported in the present paper.

An accurately weighed amount of rhodamine B (Exciton) is dissolved in methanol to give a concentration of 1.87 mmol l<sup>-1</sup>. From this stock solution, sample solutions with different concentrations ranging from 2.68 to 460 μmol l<sup>-1</sup> are prepared.

### 3. Results and discussion

The absorption, TL and fluorescence spectra of rhodamine B in methanol at a concentration of 2.68 μmol l<sup>-1</sup> are given in Fig. 2. Absorption spectrum shows the peak absorption at 18 315 cm<sup>-1</sup> and a shoulder at 19 380 cm<sup>-1</sup> which reveals two prominent vibronic levels at 546 nm (18 315 cm<sup>-1</sup>) and 516 nm (19 380 cm<sup>-1</sup>) with intensity variation as determined by Franck Condon principle. As is clear from the figure TL spectral peak

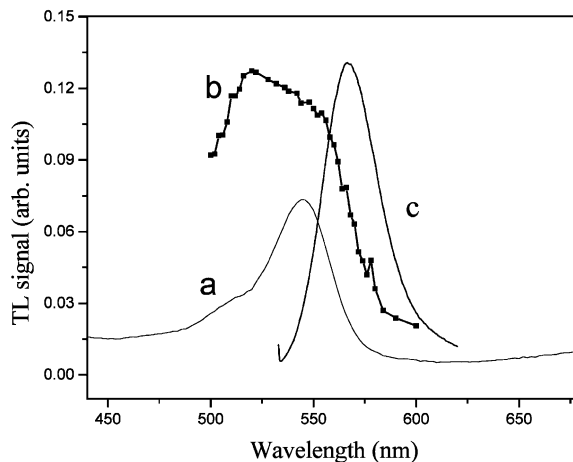

Fig. 2. Spectra of rhodamine B for a concentration of 2.68 μmol l<sup>-1</sup> in methanol (a) absorption spectrum (b) thermal lens spectrum (c) fluorescence spectrum.

and absorption peak do not coincide. The fact that these peaks do not coincide reveals the unequal magnitudes of nonradiative and radiative transition probabilities from the excited vibronic levels. Excitation to 19 380 cm<sup>-1</sup> level is followed by nonradiative de-excitations to a large number of low-lying vibronic levels. One can conclude that probability of nonradiative de-excitations from 19 380 cm<sup>-1</sup> is more than that from 18 315 cm<sup>-1</sup> level so as to get the TL spectral peak at 19 380 cm<sup>-1</sup>. This conclusion is also supported by the fact that fluorescence emission (and hence radiative relaxation cross-section) from this level is almost zero as one would expect from the complementary nature of nonradiative and radiative relaxation processes. The fluorescence peak at longer wavelength accounts for the Stokes shift [15,16].

Fig. 3 shows the spectra of rhodamine B in methanol at a concentration of 460 μmol l<sup>-1</sup>. As is evidently observed from the figure, at higher concentration there is a relative enhancement in the TL signal as compared with that in the fluorescence spectrum. With increasing dye concentration the possibility of transfer of energy between molecules by collisional mechanism makes the nonradiative part to become more prominent. Hence it is obvious that fluorescence quantum yield decreases as the concentration

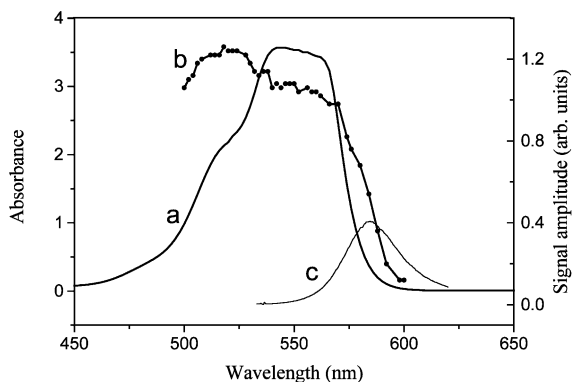

Fig. 3. Spectra of rhodamine B for a concentration of 460  $\mu\text{mol l}^{-1}$  in methanol (a) absorption spectrum (b) thermal lens spectrum (c) fluorescence spectrum.

increases [17–21]. Enhancement in nonradiative processes with increase in concentration will also take place due to reabsorption of fluorescence emission, thereby causing the red shift in the fluorescence peak (Fig. 4). Concentration dependence of TL signal (Fig. 5) from rhodamine B at various pump wavelengths also revealed same intensity results. In solutions of low concentration dyes dissolve practically completely into monomers. It should be mentioned that basic dyes like rhodamine B may dissociate at high dilutions into cations and anions. The absorption spectra are determined by the intrinsic absorption of the dye molecules and the dye–solvent interaction. At this concentration dye–dye interaction is negligible

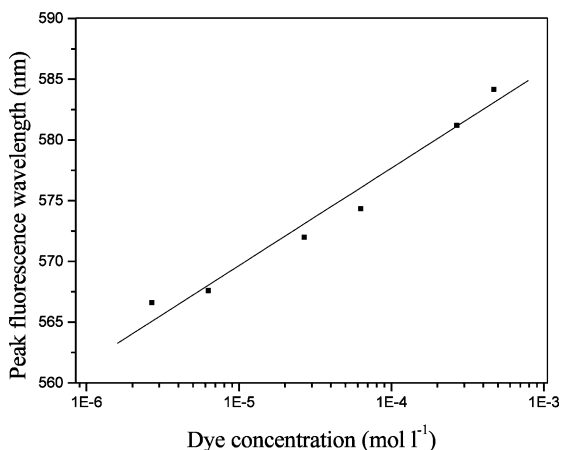

Fig. 4. The concentration dependence of peak fluorescence wavelength of rhodamine B.

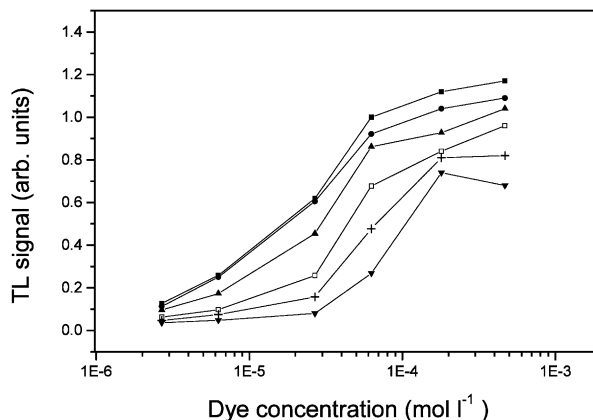

Fig. 5. Variation of TL signal amplitude of rhodamine B with concentration for different pump wavelengths (■) 520 nm (●) 540 nm (▲) 560 nm (□) 570 nm (+) 574 nm and (▼) 580 nm.

because of the large average distance between them. The absorption spectra (Fig. 3) contain contributions from the monomers and the aggregates which makes the spectrum broader at higher concentration. For highly soluble dye like rhodamine B the dye–dye interaction gains importance at high concentrations since the mean distance between them becomes small [22–24]. On increasing the concentration of dye solution, the aggregate formation and reabsorption of fluorescence emission will result into the enhancement in absorption and nonradiative relaxations at higher wavelengths. Fig. 6 shows the absorption and TL spectrum of crystal violet dye for a concentration of 6.5  $\mu\text{mol l}^{-1}$ . The absorption and the TL spectra have the same profile. This indicates that

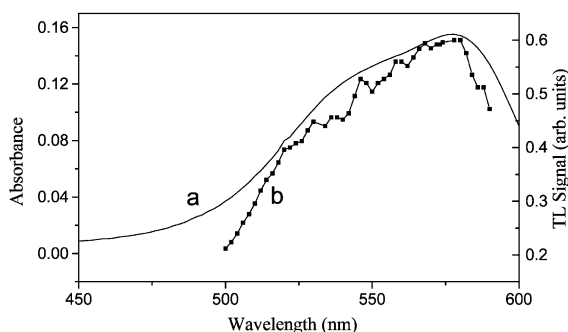

Fig. 6. Absorption (a) and thermal lens (b) spectra of crystal violet for a concentration of 65  $\mu\text{mol l}^{-1}$ .

unlike in the case of rhodamine B dye there are no intermediate vibronic levels from which nonradiative de-excitation becomes prominent. Our studies show that the simultaneous analysis of TL, absorption and fluorescence spectra will be helpful to understand relative magnitudes of nonradiative and radiative de-excitation probabilities from the excited states.

#### 4. Conclusion

Thermal lens, absorption and fluorescence spectra of rhodamine B and crystal violet were studied. It has been found that, unlike in the case of crystal violet, profiles of TL spectrum widely differ from the absorption spectrum. This is due to different radiative and nonradiative de-excitation from magnitudes of branching ratios of the upper vibronic levels. In other words, we are able to identify an intermediate vibronic level from which nonradiative de-excitation is predominant.

#### Acknowledgements

The authors are grateful to UGC (Government of India) for financial assistance. KPU and DSG are thankful to the CSIR (Government of India) for financial help. The authors also acknowledge the financial support from the Netherlands University Federation for International Collaboration (NUFFIC).

#### References

- [1] J.P. Gordon, R.C.C. Lelte, R.S. Moore, S.P.S. Porto, *J. Appl. Phys.* 36 (1965) 3.
- [2] C. Hue, J.R. Whinnery, *Appl. Opt.* 12 (1973) 72.
- [3] J.H. Brannon, D. Magde, *J. Phys. Chem.* 82 (1978) 705.
- [4] N.J. Dovichi, J.M. Harris, *Anal. Chem.* 51 (1979) 728.
- [5] M.L. Lesiecki, J.M. Drake, *Appl. Opt.* 21 (1982) 557.
- [6] M. Terazima, T. Azumi, *Chem. Phys. Lett.* 141 (1987) 237.
- [7] R.D. Snook, R.D. Lowe, *Analyst* 120 (1995) 2051.
- [8] J. Georges, J.M. Mermet, *Spectrochimica. Acta A* 49 (1993) 397.
- [9] A. Kurian, K.P. Unnikrishnan, P. Gopinath, V.P.N. Nampoore, C.P.G. Vallabhan, *J. Nonlinear Opt. Phys. Mats* 10 (2001) 415.
- [10] C.V. Bindhu, S.S. Harilal, A. Kurian, V.P.N. Nampoore, C.P.G. Vallabhan, *J. Nonlinear Opt. Phys. Mats* 7 (1998) 531.
- [11] M.E. Long, R.L. Swofford, A.C. Albrecht, *Science* 191 (1976) 183.
- [12] B.S. Seidal, W. Faubel, *J. Chromatogr. A* 817 (1998) 223.
- [13] A.J. Twarowski, D.S. Klinger, *Chem. Phys.* 20 (1977) 259.
- [14] K. Mori, T. Imasaka, N. Ishibashi, *Anal. Chem.* 54 (1982) 2034.
- [15] K.H. Drexhage, in: F.P. Shafer (Ed.), *Dye Lasers*, Springer, Berlin, 1990, p. 166.
- [16] M.L. Baesso, A.C. Bento, *Phys. Rev. B* 57 (1998) 10545.
- [17] J.N. Demas, J.A. Crosby, *J. Phys. Chem.* 75 (1971) 991.
- [18] G.G. Guilbault, *Practical Fluorescence*, Marcel Dekkar INC, New York, 1973.
- [19] J. Shen, R.D. Snook, *Chem. Phys. Lett.* 155 (1989) 583.
- [20] E.N. Bodunov, V.A. Malyshev, T.A. Shakhverdov, *Opt. Spectrosc. (USSR)* 60 (1984) 54.
- [21] C.V. Bindhu, S.S. Harilal, *Anal. Sci.* 17 (2001) 141.
- [22] P. Scherer, B. Kopainsky, *Kaiser, Opt. Commun.* 39 (1981) 375.
- [23] K. Penzkofer, H. Glas, J. Schmailzl, *Chem. Phys.* 70 (1982) 47.
- [24] L. Arbeola, *J. Chem. Soc. Faraday Trans. 2* 78 (1982) 989.